



DELOREAN MOTOR COMPANY

VEHICLE INSPECTION REPORT

15023 Eddie Drive • Humble, Texas USA 77396

281/441-2537 • 800/USA-DMC1 • 281/441-2813 : Fax • www.delorean.com

OWNER DATA

Name _____

Address _____

Phone _____ Lic No. _____ State _____ Repair No. _____

Mileage _____ VIN _____ Interior GR BL Transmission AT MT

DATE _____ MECHANIC _____

Initial Observations and Modifications _____

ROAD TEST

Check speedo operation/trip reset _____

Check for suspension and drivetrain noises and/or tire vibrations _____ Front/Rear - Left/Right _____

Check operation of all instrumentation _____

Check vehicle performance _____

Check for squeaks and rattles _____

Check for electric cool fans and A/C _____

Check for brake pedal pulse _____

Check steering column bushing-rack play _____

Check transmission (1-2, 2-3 auto/1, 2, 3, 4, 5, R manual) _____

UNDERSIDE

Check engine for: oil leaks, timing cover oil seal, timing cover Oring, rear main seal _____

Check for original and leaks: oil filter, oil pressure switch, gauge, light _____

Check automatic transmission, shift cable and final drive for fluid leaks _____

Check catalyst heatshield, muffler heatshield _____

Check for 90 amp alternator _____

Check exhaust manifold gaskets _____

Check manual transmission for fluid leaks and linkage or bushing movement _____

Check engine/transmission (mounts and brackets) _____

Check steering suspension - check play/leaks, inspect steering column universal joints and rack boots _____

Check drive shafts/side seals - Inspect boots - Check play/leaks _____

Check brake circuit - check leaks, check condition of flexible hoses _____

Check brake pads/discs - check wear/condition _____

Brake disc minimum thickness - 11.7mm LF _____ RF _____ LR _____ RR _____

Brake calipers LF _____ RF _____ LR _____ RR _____

Add'l brake comments _____

UNDERSIDE (continued)

Master cylinder seals, pistons and servo unit _____

Check and grease ball joints _____ Check ball joint boots _____

Fuel lines - check condition leaks/accumulator lines _____

Clutch - check hydraulic circuit for leaks _____

Check for installation of stainless steel clutch line _____

Check front and rear ground connections _____

Check front and rear wheel bearings _____

Check front end recall performed _____ Check crumple tube _____

Check frame for rust and condition of tie-downs (front and rear) _____

Check trailing arm bolts _____ Check air deflector plates/hardware _____

Check shock absorbers _____

Check frame for any signs of collision damage _____

Check for seat belt anchor plugs (left/right) _____

Check radiator (original or replacement), shroud and undercarriage hoses _____

ENGINE COMPARTMENT

Check operation/condition of louvre, latch and struts _____

Check engine cover condition, latch and support _____

Check engine cover grilles, mounts, hinges and decals _____

Check driving belts and A/C belt idler bearings _____

Check valve covers for leaks/valvetrain noise _____

Cooling system - Pressure test, check leaks, water pump _____

Inspect hoses: left and right, main hose, configuration early/late _____

Check automatic transmission fluid level _____

Exhaust system - check leaks/chafing, inspect muffler, brackets and clamp _____

Fuel system - check leaks.chafing, perform fuel system pressure and rest test _____ primary _____ control _____

Air conditioning - check compressor _____

Check hose condition/leaks _____

Check refrigerant level _____

Accelerator Cable - check for full throttle opening _____

Check air filter _____ intake duct hoses _____ stove pipe _____ PVC hose _____

Check de-ice recall installation _____

Check header bottle (plastic/metal) _____

Check torque on rear body mounts _____ Check coil cover _____

Check engine compartment light and switch _____

Additional comments _____

WHEELS AND TIRES	Tires - Check pressure _____
	Check cuts/damage on inside/outside walls/dry rot _____
	Check tires comply to manufacturer's specifications _____
	Check wheel alignment _____
	Wheels - Check condition of wheels and powder coating _____
	Check for correct valve stems _____
	Check for condition of wheel emblem caps _____
	Check for condition of lug nuts _____

LUGGAGE COMPARTMENT	Check for improved latch spring _____ Check operation of trunk light and struts _____
	Check/top up brake and clutch reservoir _____
	Check condition of hood seal and carpet _____
	Check windshield washer reservoir level _____
	Check condition of windshield wiper blades _____
	Check torque on front body mounts _____
	Check tool kit for completeness _____ Jack/Handle _____
	Check spare tire condition and pressure _____
	Check for fuel pump update and condition of rubber boot and cover _____

Check flexible fuel lines _____ Check inspection cover/hardware _____	

ELECTRICAL AND INSIDE CAR	Check headlamps: main/dipped beam and flashers _____
	Check parking/side lamps operation _____
	Check reverse _____ rear number plate _____ stop lights operation _____
	Check indicators/hazard warning lights operation _____
	Check interior lights (front/rear) _____
	Check horns operation _____
	Check windshield wipers and washer operation _____
	Check electric windows operation and for new style regulators wipe seals (inner/outer) _____

	Check seat belts _____
	Check operation of hand brakes _____
	Check hood release cable for fraying at end _____
Clean all fuse contacts _____	
Check for relay update installation _____	

"Electrical and Inside Car" continued ⇨

ELECTRICAL AND INSIDE CAR (continued)

- Check electric mirror operation and condition of mirrors _____
- Check electric door lock operation and escutcheon condition _____
- Check mode control switch for operation and for vacuum leaks _____
- Check A/C control panel lights _____ Decal _____
- Check blower motor operation and for noises _____ Fan speed switch _____
- Check defrost switch _____ Lighter/illumination ring _____
- Check glove box latch _____ switch _____ light _____ torsion bar for lid _____
- Check operation of electric radio antenna _____
- Check pedal pads for wear _____
- Check brake and clutch pedal linkage pivot pins for wear _____
- Check clutch master cylinder for leaks _____
- Check for armrest extensions and protectors _____
- Check radio cassette operation and speakers _____
- Check battery type, size and condition _____
- _____
- _____

EXTERIOR

- Check front and rear fascia for paint damage/warpage _____
- Check inner door seals _____ weatherstripping _____ roof seals _____
- Check door sill seals _____
- Check operation of door locks early/late style _____
- Check operation of door struts _____
- Check operation of door lights _____
- Check condition and security of body moldings _____
- Check condition of headlights and exterior lenses and screws _____
- Check condition of rock screen _____ spoiler _____
- Check windshield _____ Dropping glass _____ Fixed glass _____
- Check condition of stainless body work _____
- _____
- _____

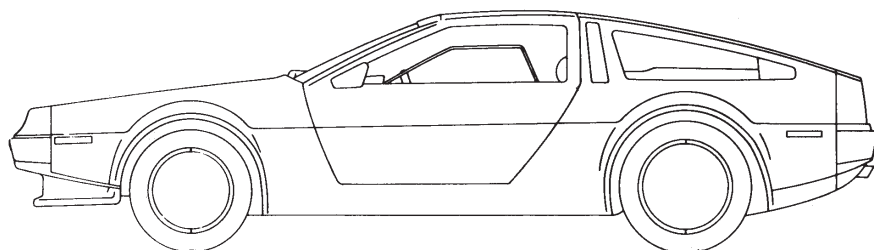

Remarks _____

Remarks _____

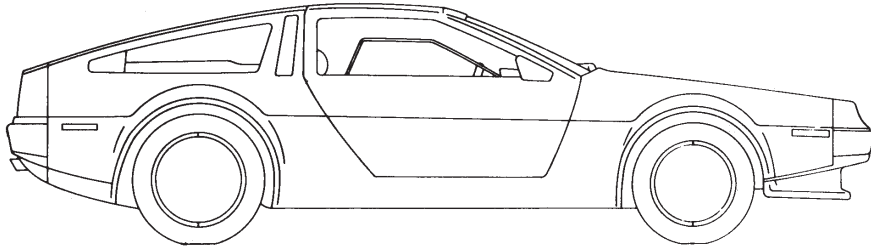

Remarks _____

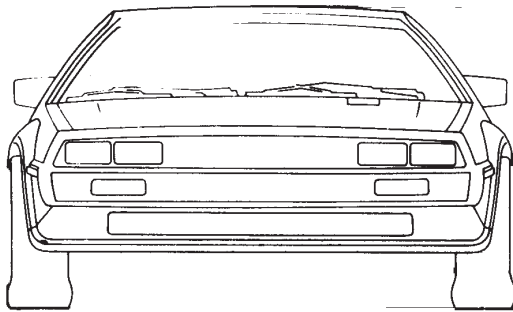

Remarks _____

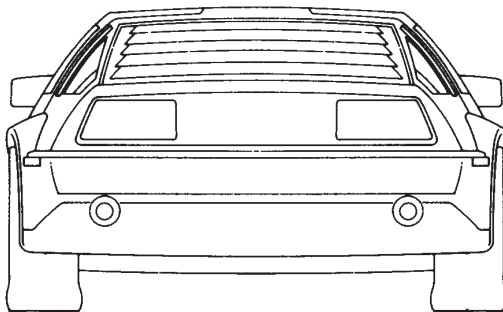

Remarks _____

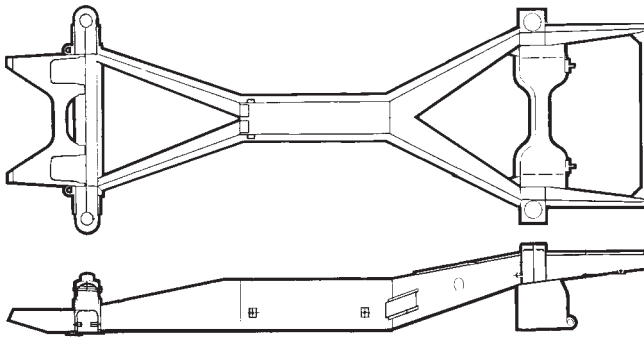

EXTERIOR

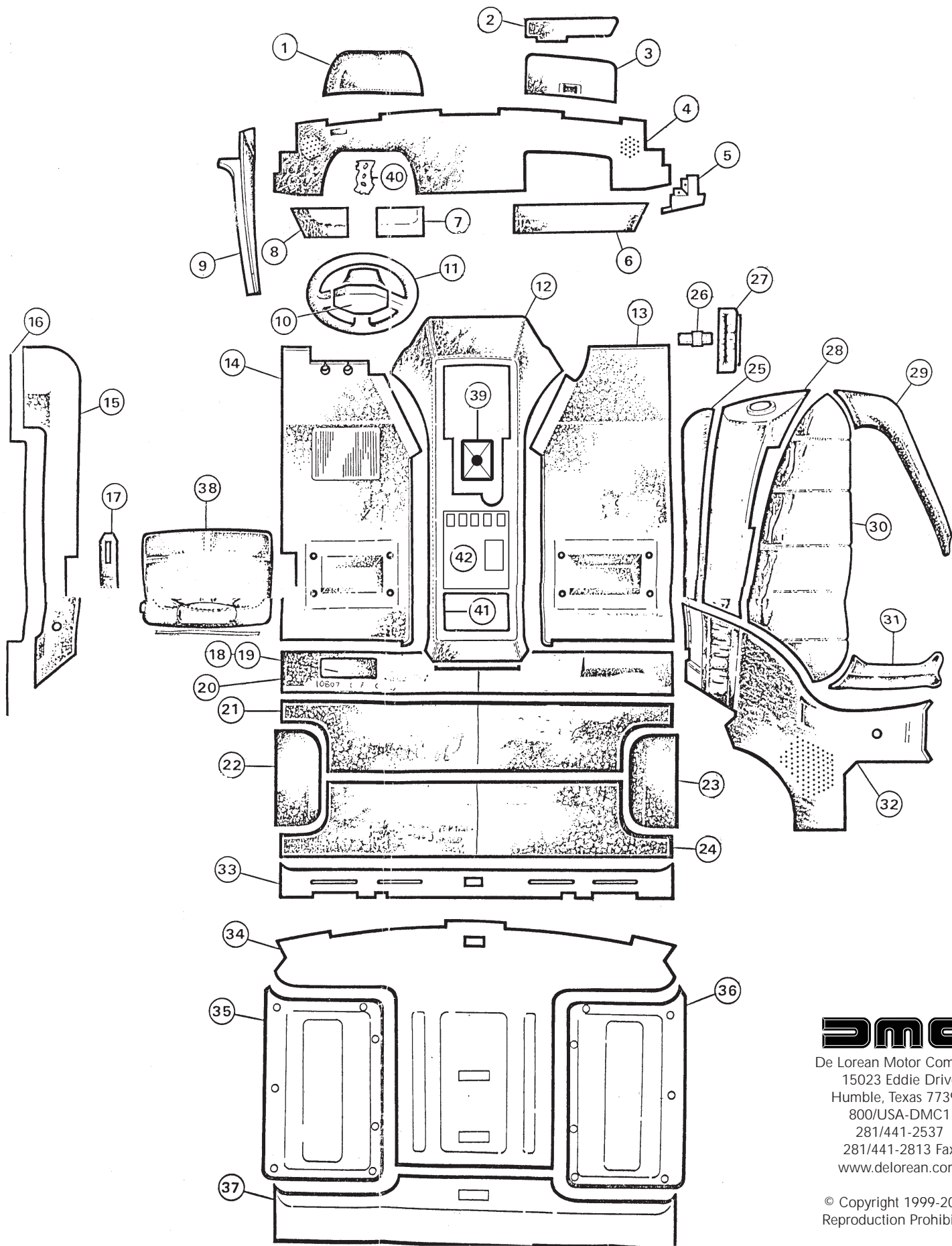

DMC
De Lorean Motor Company
15023 Eddie Drive
Humble, Texas 77396
800/USA-DMC1
281/441-2537
281/441-2813 Fax
www.delorean.com

© Copyright 1999-2003
Reproduction Prohibited.

ITEM	DESCRIPTION	BLACK P/N	GREY P/N
1	BINNACLE	101854	110436
2	SUN VISOR RH (TO 1791)	100696	---
	SUN VISOR LH (TO 1791)	100697	---
	SUN VISOR RH (FROM 1792)	100696	110216
	SUN VISOR LH (FROM 1792)	100697	110217
3	GLOVE BOX LID	101321	110438
4	DASHBOARD	105443	110440
5	DASHBOARD END, RH	105736	110442
	DASHBOARD END, LH	105737	110443
6	KNEEPAD, LH	108594	110462
7	KNEEPAD, CENTER	108592	110460
8	KNEEPAD, RH	108590	110458
9	A-POST, RH	110034	110454
	A-POST, LH	110035	110455
10	STEERING WHEEL CENTER CAP	106397	▲
11	STEERING WHEEL	106396	▲
12	CENTER CONSOLE	100683	110446

ITEM	DESCRIPTION	BLACK P/N TO 10578	GREY P/N TO 10578	BLK/GRY P/N FROM 10579
13	FLOOR, CARPET RH	108076	110464	110340
14	FLOOR, CARPET LH	108077	110465	110341
15	DOOR SILL, CARPET RH	108068	110472	110336
	DOOR SILL, CARPET LH	108069	110473	110337
16	INNER DOOR SEAL, LH OR RH	110044	▲	▲
17	PARKING BRAKE COVER	108070	110478	110352
18	STORAGE COMPARTMENT CARPET	105529	110476	110333
19	STORAGE COMPARTMENT LID	108004	110484	109246
20	DECK BOARD, CARPET	108075	110480	110355
21	REAR SHELF, CARPET	108067	110482	110357
22	WHEEL ARCH LH	108085	110869	110345
23	WHEEL ARCH RH	108084	110468	110344
24	BULKHEAD CARPET	108204	110852	109251
25	DOOR CARPET, RH	108082	111336	112336
	DOOR CARPET, LH	108083	111337	112337

ITEM	DESCRIPTION	BLACK P/N	GREY P/N
26	PULL STRAP, WITH RING	108658	111024
	PULL STRAP, NO RING	110308	110309
27	GRAB HANDLE, RH	108062	111028
	GRAB HANDLE, LH	108061	111029
28	ARMREST, RH (TO 5992)	110168	110508
	ARMREST, LH (TO 5992)	110169	110509
	ARMREST, RH (FROM 5993)	111298	110250
	ARMREST, LH (FROM 5993)	111299	110249
29	A-POST, DOOR RH	101876	110494
	A-POST, DOOR LH	101877	110495
30	DOOR PANEL, UPPER RH	110174	110504
	DOOR PANEL, UPPER LH	110175	110505
31	B-POST, DOOR RH	101878	110500
	B-POST, DOOR LH	101879	110501
32	TRIM PANEL, REAR RH (TO 6092)	110170	110428
	TRIM PANEL, REAR LH (TO 6092)	110171	110429
	TRIM PANEL, REAR RH (FROM 6093)	110676	110252
	TRIM PANEL, REAR LH (FROM 6093)	110677	110251
33	REAR TRIMBOARD	106201	110486
34	HEADLINER, FRONT	105191	110059
35	HEADLINER, DOOR LH	105753	110063
36	HEADLINER, DOOR RH	105754	110062
37	HEADLINER, REAR	105192	110060
38	SEAT ASSY, RH	100600	110516
	SEAT ASSY, LH	100601	110517
	SEAT BOTTOM, RH	101622	111258
	SEAT BOTTOM, LH	101623	111259
	SEAT BACK, RH	101624	111266
	SEAT BACK, LH	101625	111267
	SEAT REAR PANEL LH OR RH	105271	109255
39	GEAR SHIFT BOOT, W/FRAME	100688	▲
40	STEERING COLUMN GAITER	108706	111706
41	COIN TRAY	108232	110521
42	ARMREST, CENTER CONSOLE	108239	110523

DE LOREAN MOTOR COMPANY

Service Recommendations

- 01010 Lube, Oil, Filter** **Recommended**
- 01003 7,500 Mile Service** **Recommended**
Underside: Drain and refill engine oil, replace oil filter. Inspect steering suspension, drive shafts, gearbox/sump/timing cover, front and rear shocks, brake circuit and flexible hoses, brake pads/discs, fuel lines, clutch, clutch line, ground connections, trailing arm bolts, front/rear wheel bearings.
Engine Compartment: Check drive belts, rocker cover. Check leaks and security of exhaust system. Check fuel system for leaks, chafing. Check air conditioning pipe condition/leaks, check idler bearings. Check for deice recall installation. Check header bottle.
Wheels and Tires: Check pressures, specifications and conditions of tires. Torque wheels nuts. Check/fill brake and clutch reservoirs.
Electrical/Inside car: Check headlamps, (main and dipped beam). Check operation of flashers, reverse lights, parking/side lights, license plate lights, stop lights, turn signal indicators, internal luggage and engine compartment lights, horns, windshield wipers and washer. Check condition/security of seat belts. Check operation of hand brake, hood/engine cover release (note condition of cable). Check mode control switch operation/vacuum leaks, blower motor operations/noises. Check condition of seats/soft trim, wear on pedal pads.
Exterior: Check front/rear fascias and stainless panels for damage. Check all door seals. Check operation of door, louvre, and hood struts.
Luggage Compartment: Check condition of hood seal, and washer fluid reservoir level. Check spare tire condition and pressure.
Road Test: Check operation of all instrumentation, vehicle performance, squeaks/rattles, and operation of electric cooling fans.
- 01004 15,000 Mile Service** **Recommended**
Underside: 7,500 Mile Service actions and: Drain/refill automatic transmission fluid. Drain/refill manual transmission oil. Check condition of brake servo filter. Grease ball joints.
Engine Compartment: 7,500 Mile Service actions and: Drain and refill cooling system. Check accelerator cable, lubricate linkages. Check initial timing and vacuum advance. Check torque on rear body mount bolts.
Luggage Compartment: 7,500 Mile Service actions and: Check torque on front body mount bolts.
- 01006 30,000 Mile Service (Manual)** **Recommended**
Underside: 15,000 Mile Service actions and: Tighten sump bolts. Check ground connections. Replace fuel filter and oxygen sensor.
Engine Compartment: 15,000 Mile Service actions and: Adjust rocker arm clearance if necessary. Check engine CO and HC levels, adjusting if necessary. Check/replace as necessary: Oxygen sensor, coil wire, belts, distributor cap/rotor, plugs, plug wires.
Wheels and Tires: 15,000 Mile Service actions and: Check wheel alignment.
Electrical/Inside car: 15,000 Mile Service actions and: Check fuse contacts. Check brake/clutch pedal linkage pivot pins for wear. Reset service interval counter. Check battery tie-down.
Luggage Compartment: 15,000 Mile Service actions and: Check fuel pump installation. Check tool kit/jack for completeness.
- 01009 30,000 Mile Service (Automatic)** **Recommended**
Same as 01006 except: Service automatic transmission. Check/adjust governor cable. Replace transmission filter.
- 13102 - Flush/Fill/Bleed Cooling System** **Recommended**
- 63008 - Flush/Fill/Bleed Brake Fluid** **Recommended**
- 72001 - Service Air Conditioning** **Recommended**